

PATENT SPECIFICATION

408,766

Application Date: Jan. 14, 1933. No. 1298/33.

Complete Left: Nov. 25, 1933.

Complete Accepted: April 19, 1934.

PROVISIONAL SPECIFICATION.



Apparatus for Surfacing Sheet Material with Pigments and the like.

I, HENRY TAYLOR WYSE, of 1, Craigleith Grove, Blackhall, Edinburgh, of British Nationality, do hereby declare the nature of this invention to be as follows:—

This invention relates to apparatus for surfacing sheet material with pigments and the like, more particularly apparatus for surfacing sheets of paper by a so-called process of marbling which consists in applying a sheet of paper to colours floating on the surface of an aqueous solution accommodated in a so-called marbling bath.

Apparatus of this type as constructed heretofore includes a rotary annular trough accommodating the aqueous solution and equipped with means for applying the surface of a web of paper to the surface of the solution in the trough, with means for delivering colours to the surface of the solution in the trough and with means for stirring the solution.

The present invention provides an improved apparatus for carrying out the process above referred to comprising an apparatus in which the solution-receiving trough is constituted by the upper flight

of a horizontally disposed travelling endless band supported by two or more rollers and bounded on each side by an integral or separate ridge and in which the web of paper or other sheeted material is fed continuously on to the surface and pulled away continuously from the surface of the solution travelling on the upper flight of the band, there being associated with the travelling band means for delivering solution on to the travelling band, means for collecting solution discharged from the travelling band and means for returning discharged solution to the point of delivery.

There is located above the travelling band suitable means for depositing colours on the solution and suitable devices for stirring the solution in its passage towards the web of paper to be coated.

Dated this 13th day of January, 1933.
CRUIKSHANK & FAIRWEATHER,
29, Saint Vincent Place, Glasgow,
and
65/66, Chancery Lane, London, W.C.2,
Agents for the Applicant.

COMPLETE SPECIFICATION.

Apparatus for Surfacing Sheet Material with Pigments and the like.

I, HENRY TAYLOR WYSE, of 1, Craigleith Grove, Blackhall, Edinburgh, of British Nationality, do hereby declare the nature of this invention and in what manner the same is to be performed, to be particularly described and ascertained in and by the following statement:—

This invention relates to apparatus for surfacing sheet material with pigments and the like, more particularly apparatus for surfacing sheets of paper by a so-called process of marbling which consists in applying a sheet of paper to colours floating on the surface of an aqueous solution accommodated in a so-called marbling bath.

Apparatus of this type as constructed heretofore includes a rotary annular trough accommodating the aqueous solu-

[Price 1/-]

tion and equipped with means for applying the surface of a web of paper to the surface of the solution in the trough, with means for delivering colours to the surface of the solution in the trough and with means for stirring the solution.

The present invention provides an improved apparatus for carrying out the process above referred to comprising an apparatus in which the solution-receiving trough is constituted by the upper flight of a horizontally disposed travelling endless band supported by two or more rollers and bounded on each side by an integral or a separate ridge and in which the web of paper or other sheeted material is fed continuously on to the surface and pulled away continuously from the surface of the solution travelling on the upper flight

Price 4s 6d

of the band, there being associated with the travelling band means for delivering solution on to the travelling band, means for collecting solution discharged from the travelling band and means for returning discharged solution to the point of delivery.

There is located above the travelling band suitable means for depositing colours on the solution and suitable devices for stirring the solution in its passage towards the web to be coated.

An apparatus constructed in accordance with the invention is illustrated in the accompanying drawings in which Fig. 1 is a vertical section, Fig. 2 a plan, Fig. 3 a plan drawn to a larger scale and showing certain forms of colour depositing means and stirring devices, and Figs. 4, 5 and 6 are sections respectively on the line 4-4, 5-5, and 6-6 of Fig. 3.

The apparatus shown comprises a solution-receiving trough 1 constituted by the upper flight of a horizontally disposed travelling endless band 2 supported by two rollers 3, 4, and a table 2^a, and bounded on each side by an integral ridge 5. The roller 3 is carried by a shaft 6 whereon are mounted pulley-wheels 7, 8, 9, the pulley-wheels 9 being connected by a belt 10 to the shaft 11 of an electric motor 12.

A web 13 of paper or other sheeted material to be surfaced is guided continuously on to the surface of the solution travelling on the band 2 by means of a pick-up roller 14 and is propelled across the surface by means of a rotary drum 15 deriving rotation from the pulley 7 by means of a pulley 16 and a belt 17. Preferably, the drum 15 is internally heated so that it may serve as a drying drum. The paper is supplied from a reel 18 and is picked up by a reel 19 driven by gearing 20, a friction clutch pulley 21 and a belt 22 connected to a pulley 23 on the motor shaft 11.

The solution is delivered on to the trough 1 through a sluice-controlled aperture 24 in a head-box 25 and is removed from the surface of the band by means of a doctor 26. The solution flows into a reservoir 27 located below the doctor 26 and is returned by a pump 28 through a conduit 29 into the head-box 25, there being interposed between the pump 28 and the reservoir a strainer 30. 31 denotes an overflow pipe for conveying excess solution from the head-box 25 to the reservoir 27. 32 denotes a doctor for removing excess solution from the coated surface of the web 13 and conveying the solution to the reservoir 27.

It will be readily understood that, by adjustment of the sluice-controlled aper-

ture 24, the solution may be constrained to flow into the trough and to travel in the direction of rotation of the endless band as indicated by the arrow 33 so that there may be presented a regular stream of solution for the reception of the deposited colours as hereinafter described. The gear ratio between the pulleys 7 and 16 is so arranged that the surface speed of the web is substantially identical with the surface speed of the solution flowing in the direction of the arrow 33.

There is located above the upper flight of the travelling band 2 a colour bath 34 containing liquid colour in which is immersed a roller 35 deriving rotation from the shaft 6 through the pulley 8, a belt 36, a counter-shaft 37, bevel gearing 38, a shaft 39 and bevel gearing 40. Associated with the roller is a doctor provided with fingers 50 over which liquid colour scraped from the surface of the roller 35 is constrained to flow in a series of fine streams or in drops on to the surface of the solution. Located above the upper flight of the band 2 is a transverse stirrer 41 which is formed as a follower to a cam 42 on the shaft 39 and is caused by such cam to reciprocate transversely of the band. The stirrer is provided with prongs 43 dipping into the solution. It will be readily understood that, in the reciprocation of the stirrer, there are produced in the surface of the stream waves of colour deposited by the fingers

50. Located also above the upper flight of the band 2 is a supplementary stirrer comprising a plurality of stirring fingers 44 dipping into the solution and carried by an endless band 45 which is entrained over rollers 46 driven by pulleys 47 embraced by a rope 48 which, in turn, is driven by a pulley 49 deriving rotation from the shaft 39.

It will be understood that the stirring devices herein described are to be treated as examples and that they may be replaced by any other suitable stirring device.

Suitable solutions for use in the apparatus described comprise carrageen or Irish moss (*Chondrus crispus*) dissolved in water or gum tragacanth dissolved in water.

Having now particularly described and ascertained the nature of my said invention and in what manner the same is to be performed, I declare that what I claim is:—

(1) An apparatus of the type referred to for surfacing sheet material with pigments and the like, in which the solution-receiving trough is constituted by the upper flight of a horizontally disposed travelling endless band supported by two or more rollers and bounded on each side

70

75

80

85

90

95

100

105

110

115

120

125

130

by an integral or a separate ridge and in which the web of paper or other sheeted material is fed continuously on to the surface and pulled away continuously from the surface of the solution travelling on the upper flight of the band, there being associated with the travelling band means for delivering solution on to the travelling band, means for collecting solution discharged from the travelling band, and means for returning discharged solution to the point of delivery.

(2) An apparatus according to claim 1

in which there is located above the travelling band suitable means for depositing colours on the solution and suitable devices for stirring the solution in its passage towards the web to be coated.

(3) The herein described and illustrated apparatus for surfacing sheet material with pigments and the like.

Dated this 24th day of November, 1933.
 CRUIKSHANK & FAIRWEATHER,
 86, St. Vincent Street, Glasgow,
 and
 65/66, Chancery Lane, London, W.C.2,
 Agents for the Applicant.

[This Drawing is a reproduction of the Original on a reduced scale.]

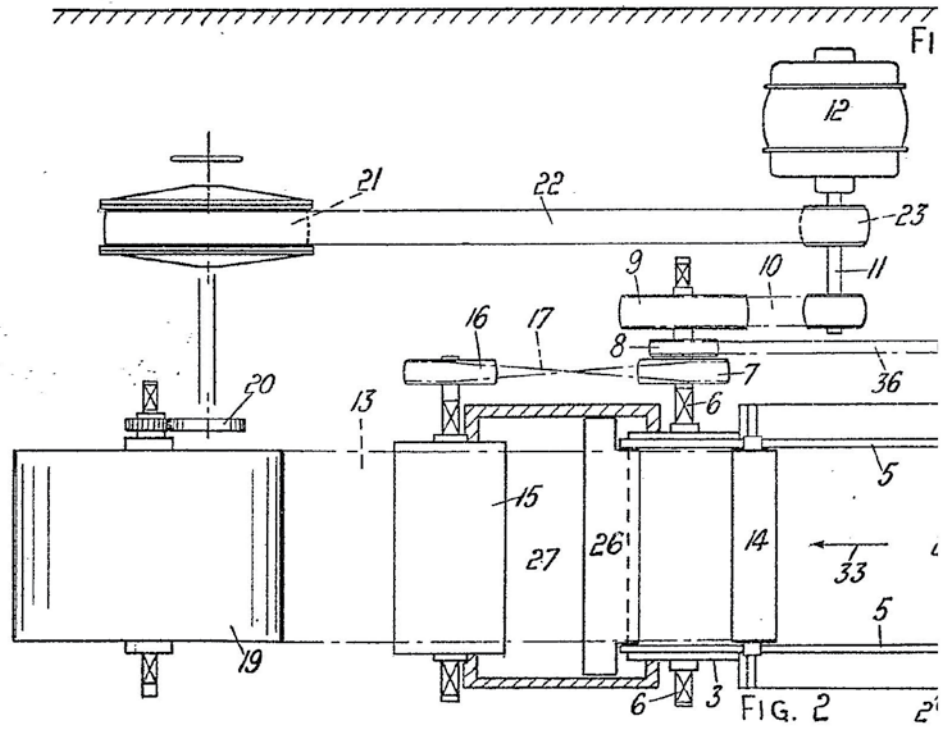
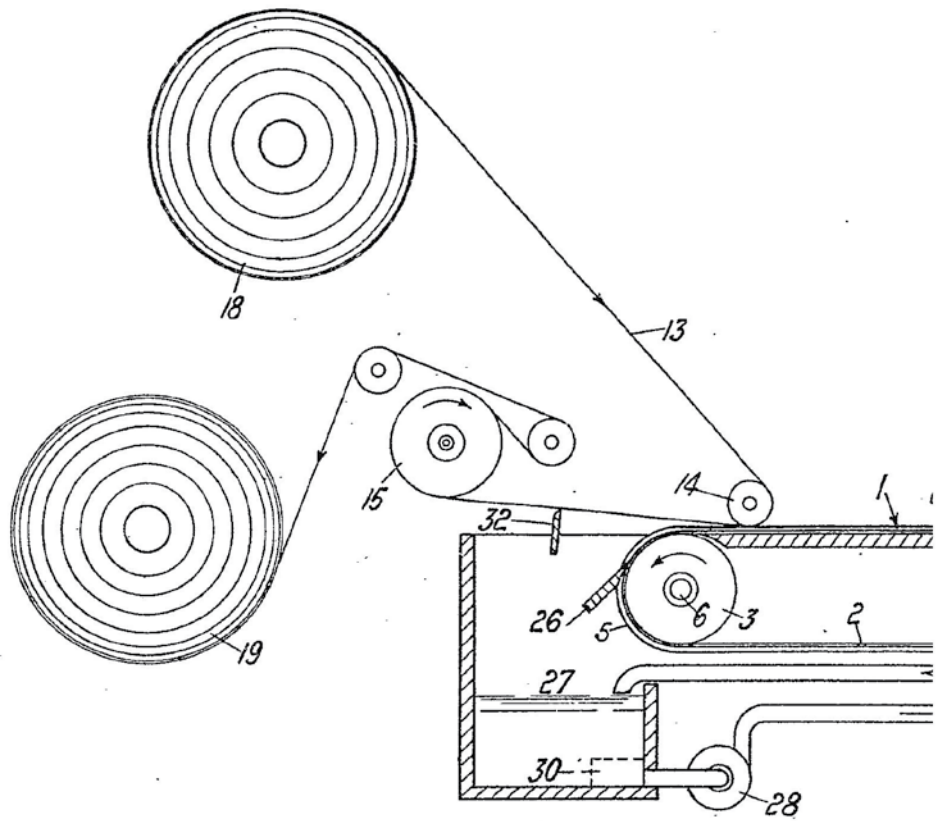

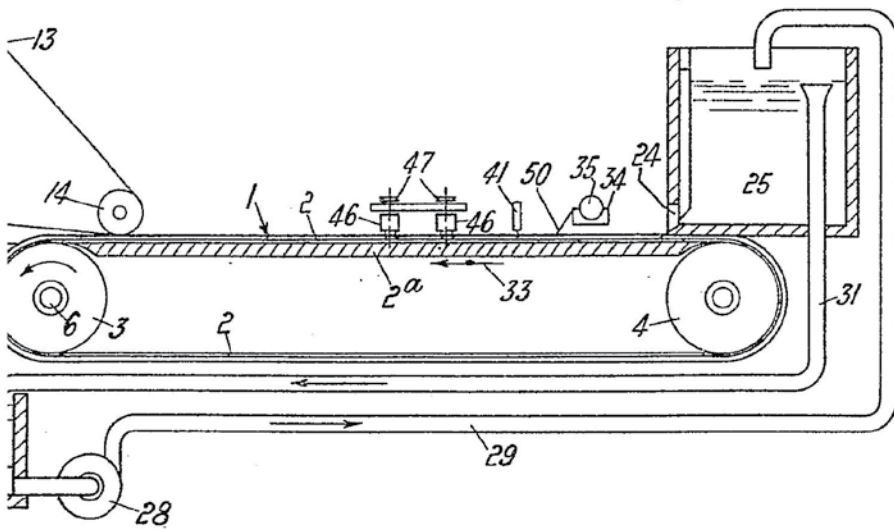

FIG. 1.

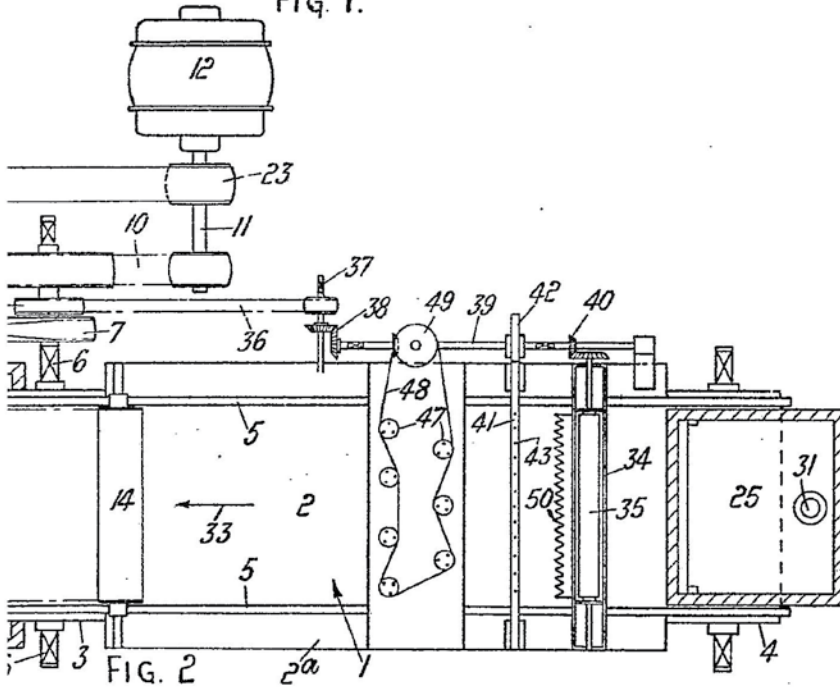
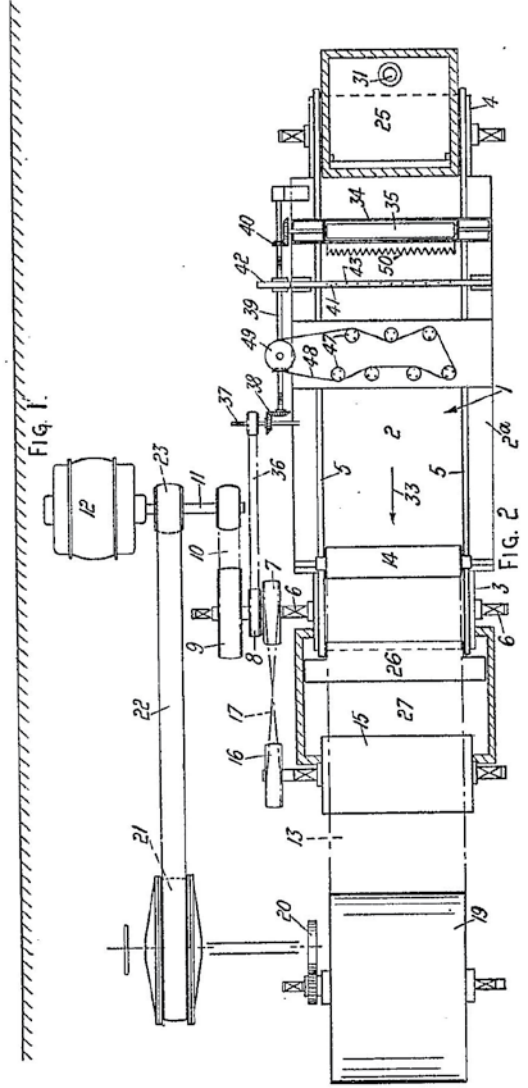
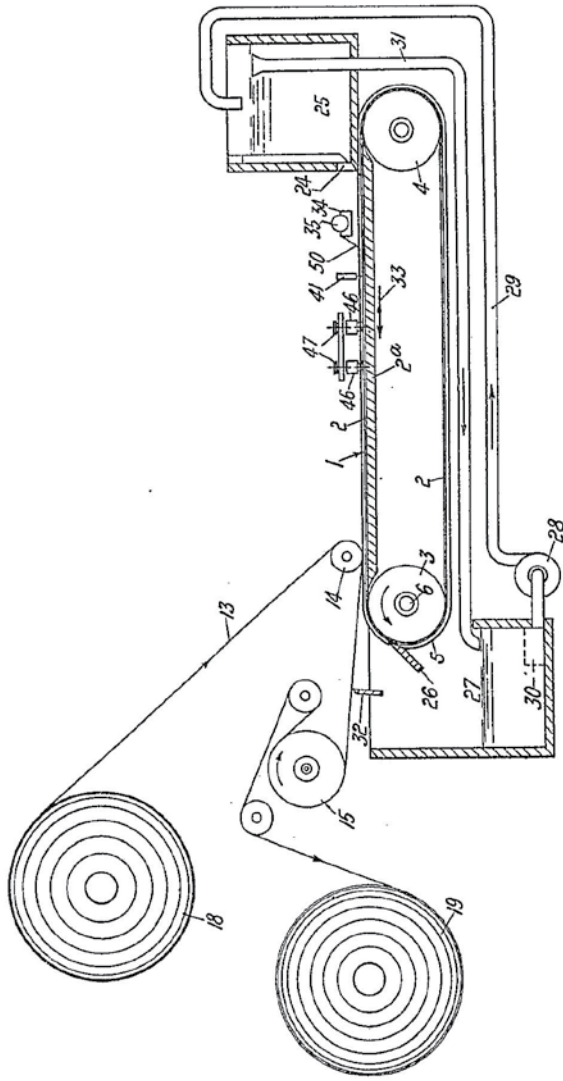

FIG. 2

408,766 COMPLETE SPECIFICATION



[This Drawing is a reproduction of the Original on a reduced scale.]

[This Drawing is a reproduction of the Original on a reduced scale.]

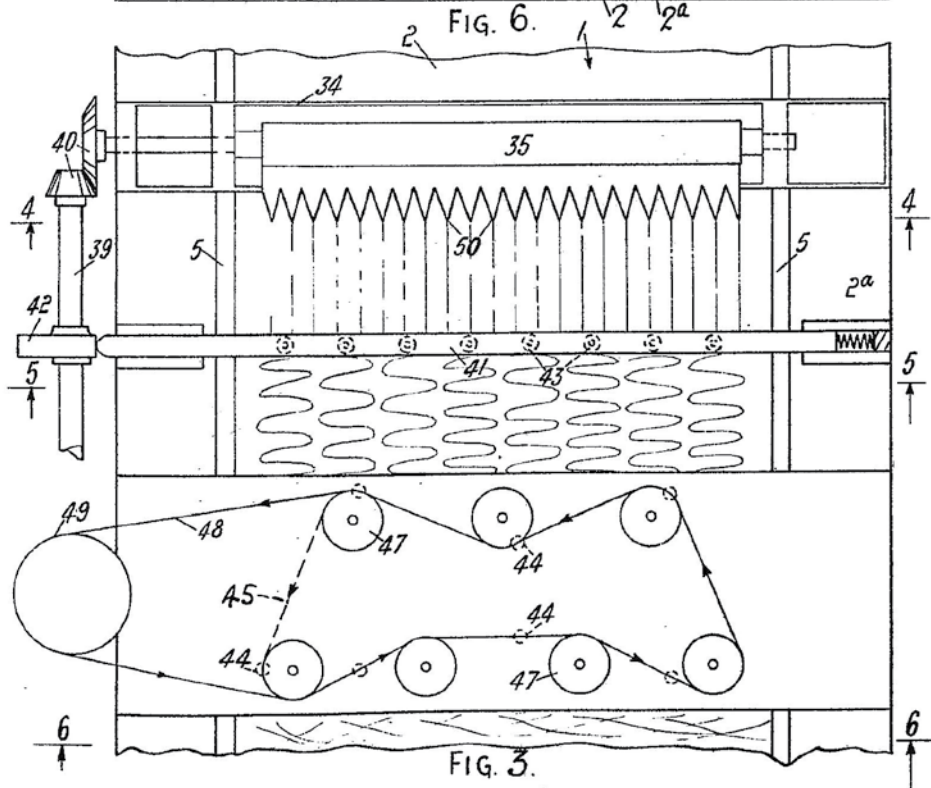
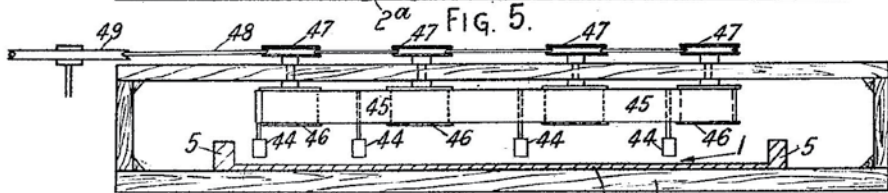
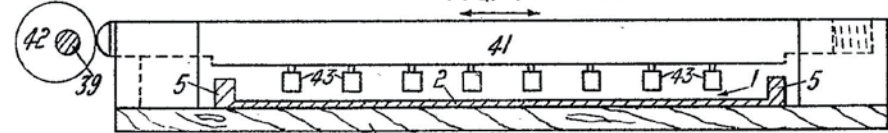
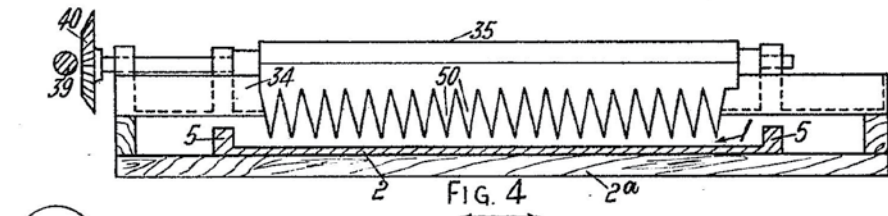

346316

This invention relates to apparatus for surfacing sheet material with pigments and the like, more particularly apparatus for surfacing sheets of paper by a so-called process of marbling which consists in applying a sheet of paper to colours floating on the surface of an aqueous solution accommodated in a so-called marbling bath.

Apparatus of this type as constructed heretofore includes a rotary annular trough accommodating the aqueous solution and equipped with means for applying the surface of a web of paper to the surface of the solution in the trough, with means for delivering colours to the surface of the solution in the trough and with means for stirring the solution.

The present invention provides an improved apparatus for carrying out the process above referred to comprising an apparatus in which the solution-receiving trough is constituted by the upper flight of a horizontally disposed travelling endless band supported by two or more rollers and bounded on each side by an integral or a separate ridge and in which the web of paper or other sheeted material is fed continuously on to the surface and pulled away continuously from the surface of the solution travelling on the upper flight of the band, there being associated with the travelling band means for delivering solution on to the travelling band, means for collecting solution discharged from the travelling band, and means for returning discharged solution to the point of delivery.

346816

There is located above the travelling band suitable means for depositing colours on the solution and suitable devices for stirring the solution in its passage towards the web to be coated.

An apparatus constructed in accordance with the invention is illustrated in the accompanying drawings in which Fig.1 is a vertical section, Fig.2 a plan, Fig.3 a plan drawn to a larger scale and showing certain forms of colour depositing means and stirring devices, and Figs.4, 5 and 6 are sections respectively on the line 4-4, 5-5, and 6-6 of Fig.3.

The apparatus shown comprises a solution-receiving trough 1 constituted by the upper flight of a horizontally disposed travelling endless band 2 supported by two rollers 3,4 and a table 2^a, and bounded on each side by an integral ridge 5. The roller 3 is carried by a shaft 6 whereas are mounted pulley-wheels 7,8,9, the pulley-wheel 9 being connected by a belt 10 to the shaft 11 of an electric motor 12.

A web 13 of paper or other sheeted material to be surfaced is guided continuously on to the surface of the solution travelling on the band 2 by means of a pick-up roller 14 and is propelled across the surface by means of a rotary drum 15 deriving rotation from the pulley 7 by means of a pulley 16 and a belt 17. Preferably, the drum 15 is internally heated so that it may serve as a drying drum. The paper is supplied from a reel 18 and is picked up by a reel 19 driven by gearing 20, a friction clutch pulley 21 and a belt 22 connected to a pulley 23 on the motor shaft 11.

The solution is delivered on to the trough 1 through a sluice-controlled aperture 24 in a head-box 25 and is removed from the surface of the band by means of a doctor 26. The solution flows into a reservoir 27 located below the doctor 26 and is returned by a pump 28 through a conduit 29 into the head-box 25, there being interposed between the pump 28 and the reservoir a strainer 30. 31 denotes an overflow pipe for conveying excess solution from the head-box 25 to the reservoir 27. 32 denotes a doctor for removing excess solution from the coated surface of the web 13 and conveying the solution to the reservoir 27.

It will be readily understood that, by adjustment of the sluice-controlled aperture 24, the solution may be constrained to flow into the trough and to travel in the direction of rotation of the endless band as indicated by the arrow 33 so that there may be presented a regular stream of solution for the reception of the deposited colours as hereinafter described. The gear ratio between the pulleys 7 and 16 is so arranged that the surface speed of the web is substantially identical with the surface speed of the solution flowing in the direction of the arrow 33.

There is located above the upper flight of the travelling band 2 a colour bath 34 containing liquid colour in which is immersed a roller 35 deriving rotation from the shaft 6 through the pulley 8, a belt

36, a counter-shaft 37, bevel gearing 38, a shaft 39 and bevel gearing 40. Associated with the roller is a doctor provided with fingers 50 over which liquid colour scraped from the surface of the roller 35 is constrained to flow in a series of fine streams or in drops on to the surface of the solution. Located above the upper flight of the band 2 is a transverse stirrer 41 which is formed as a follower to a cam 42 on the shaft 39 and is caused by such cam to reciprocate transversely of the band. The stirrer is provided with prongs 43 dipping into the solution. It will be readily understood that, in the reciprocation of the stirrer, there are produced in the surface of the stream waves of colour deposited by the fingers 50.

Located also above the upper flight of the band 2 is a supplementary stirrer comprising a plurality of stirring fingers 44 dipping into the solution and carried by an endless band 45 which is entrained over rollers 46 driven by pulleys 47 embraced by a rope 48 which, in turn, is driven by a pulley 49 deriving rotation from the shaft 39.

It will be understood that the stirring devices herein described are to be treated as examples and that they may be replaced by any other suitable stirring devices.

Suitable solutions for use in the apparatus described comprise carrageen or Irish moss (*Chondrus crispus*) dissolved in water or gum tragacanth dissolved in water.

1
What I claim is:-

(1) An apparatus of the type referred to for surfacing sheet material with pigments and the like, comprising, in combination, a solution-receiving trough constituted by the upper flight of a horizontally disposed travelling endless band provided with ridges located one on each side, two or more rollers, means for feeding the web of paper or other sheeted material continuously on to the surface and pulling said web away continuously from the surface of the solution travelling on said upper flight, means for delivering solution on to said band, means for collecting solution discharged from said band, and means for returning discharged solution to the point of delivery.

(2) An apparatus of the type referred to for surfacing sheet material with pigments and the like, comprising, in combination, a solution-receiving trough constituted by the upper flight of a horizontally disposed travelling endless band provided with ridges located one on each side, two or more rollers, means for feeding the web of paper or other sheeted material continuously from the surface of the solution travelling on said upper flight, means for delivering solution on to said band, means for collecting solution discharged from said band, means for returning discharged solution to the point of delivery, means located in said band for depositing colours on to said solution and means for stirring the solution in its passage towards said web.

9

346316

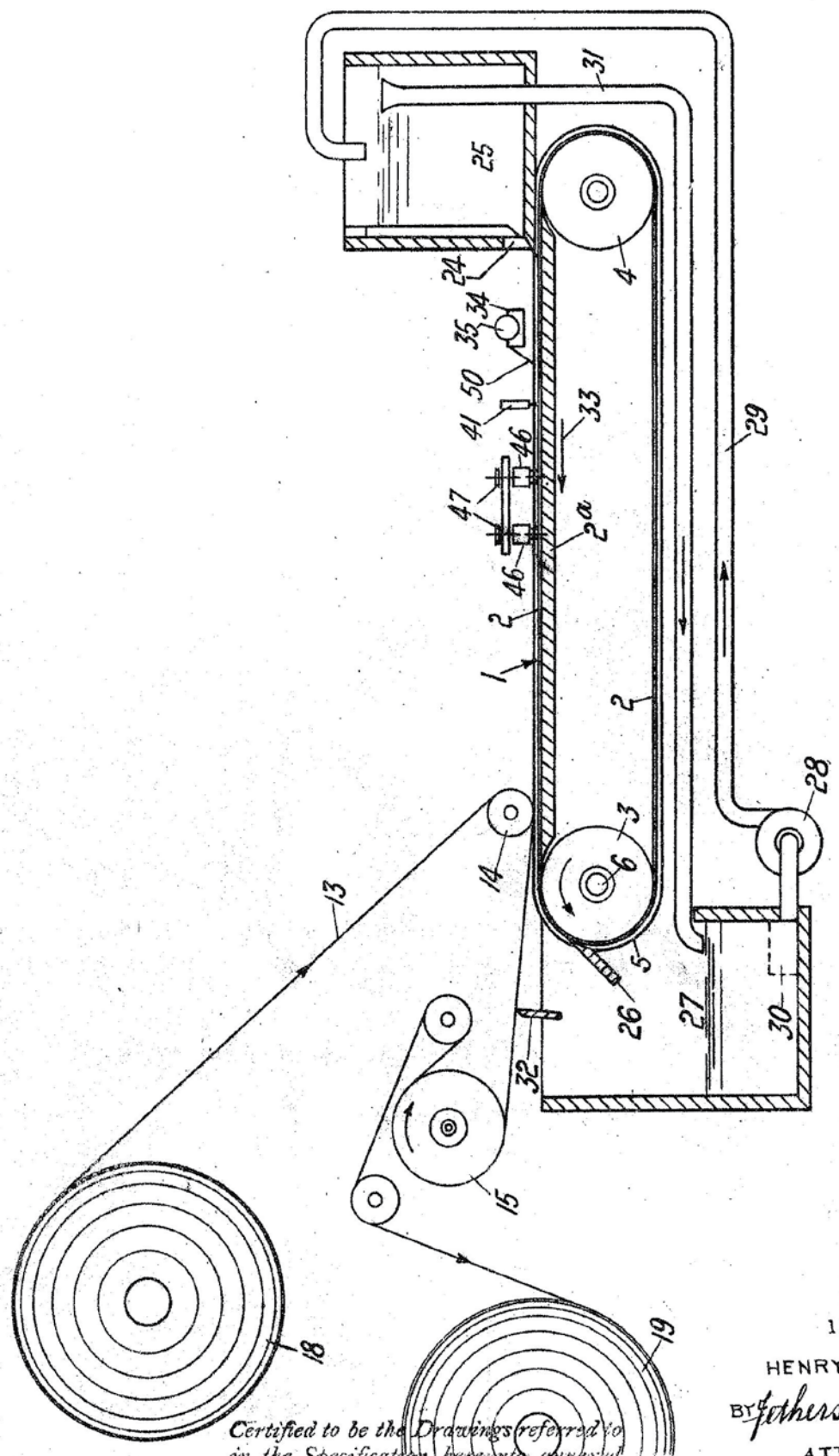

FIG. 1.

INVENTOR
 HENRY TAYLOR WYSE
 BY *Fatherstonhaugh & Co.*
 ATTORNEYS

*Certified to be the Drawings referred to
 in the Specification hereinto annexed*

MONTREAL MAR. 2nd 1934

346316

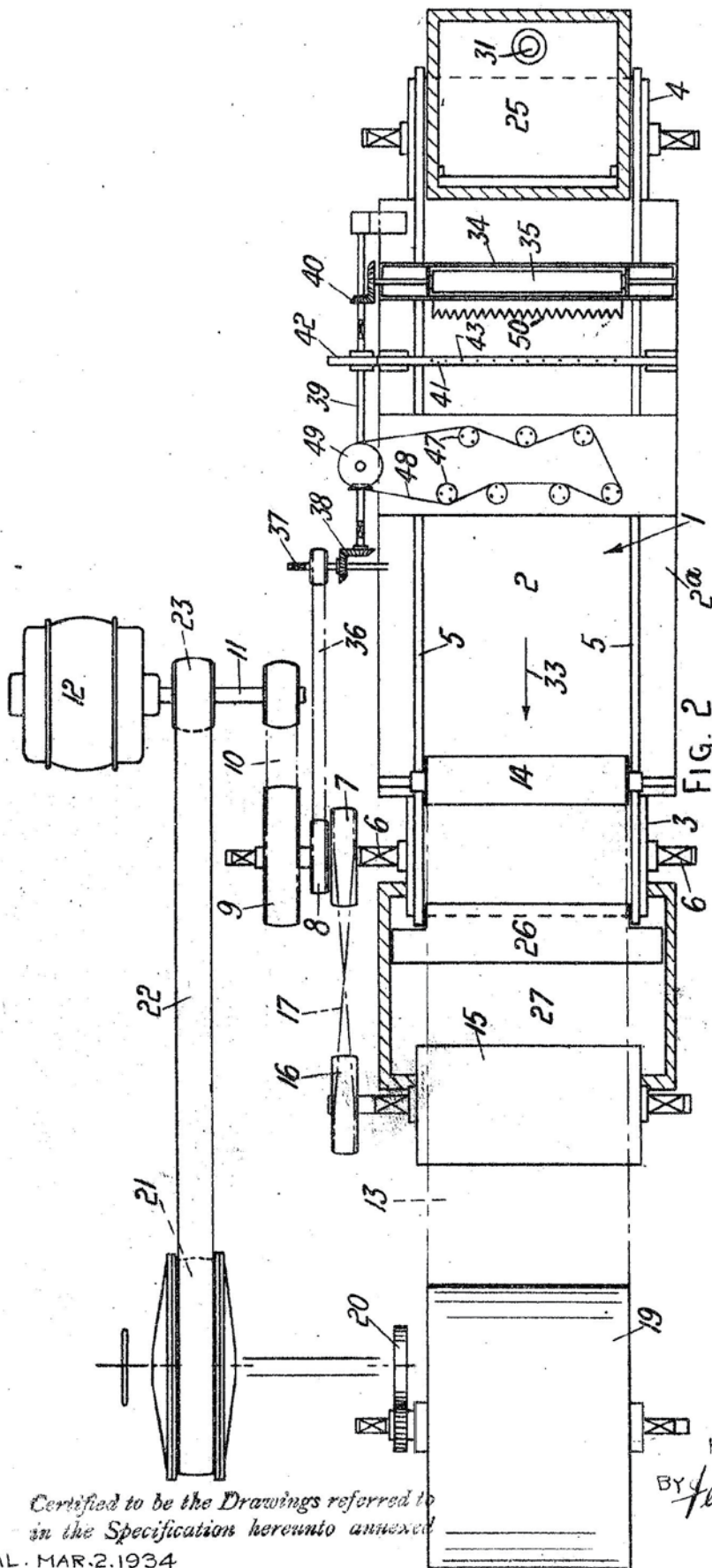

FIG. 2

Certified to be the Drawings referred to in the Specification hereunto annexed

MONTREAL, MAR. 2, 1934

INVENTOR
HENRY TAYLOR WYSE
BY *Fetherstonhaugh & Co*
ATTORNEYS

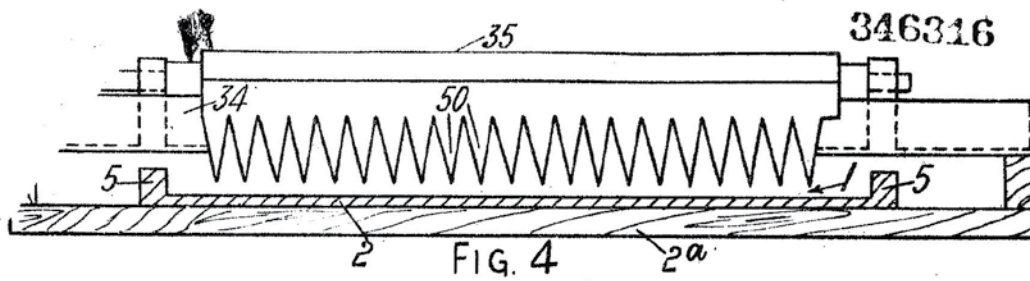

FIG. 4

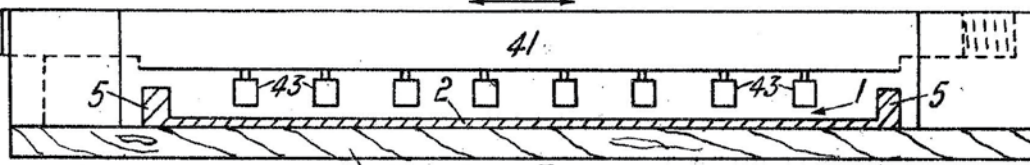

FIG. 5

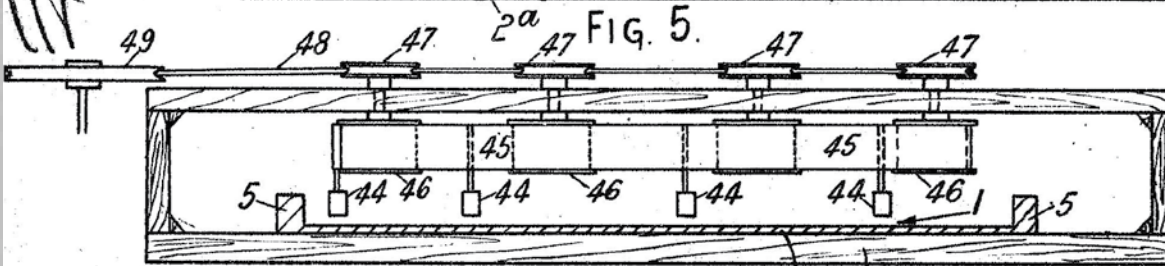

FIG. 6

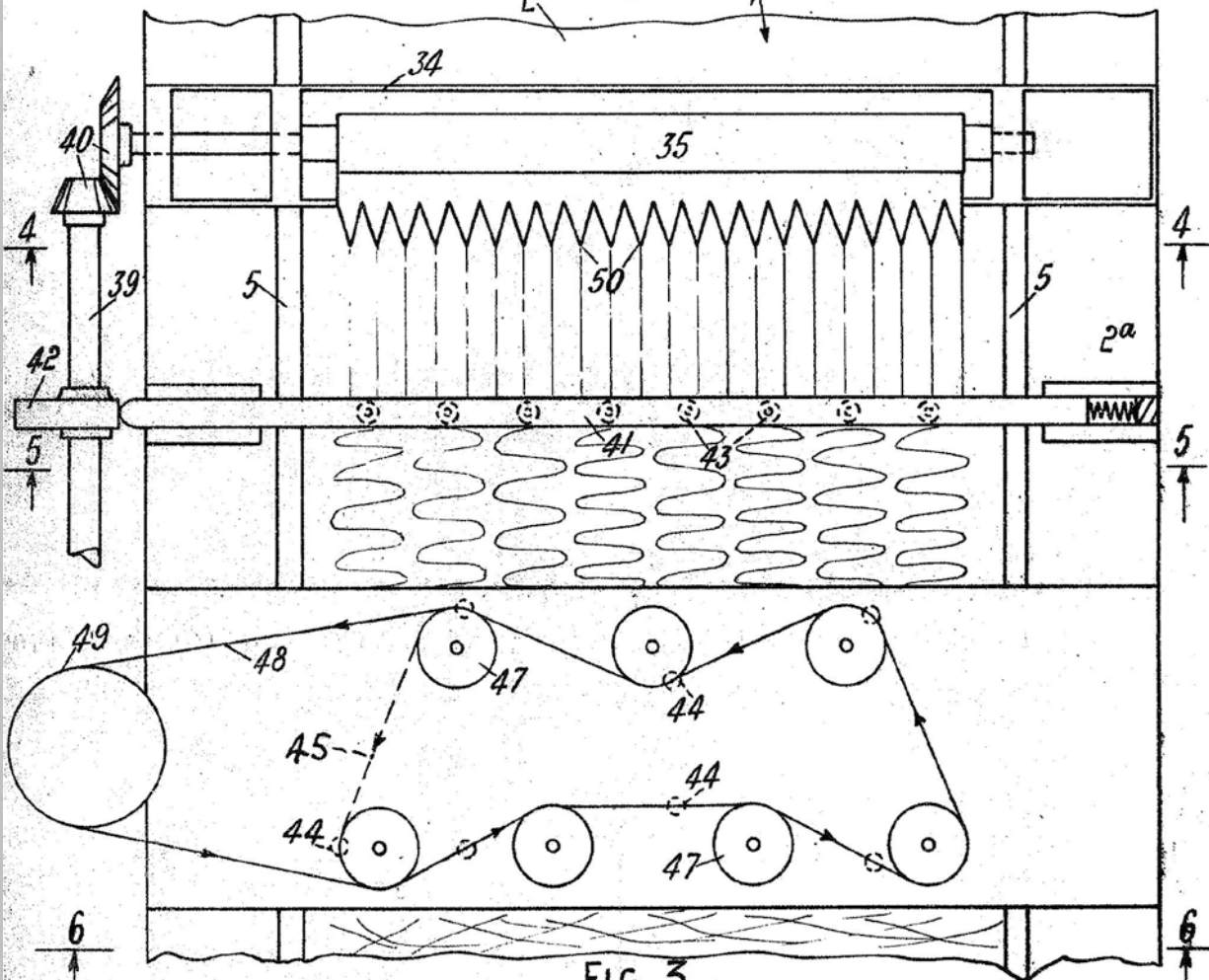

FIG. 3

INVENTOR

HENRY TAYLOR WYSE

BY *Fetherstonhaugh & Co.*

ATTORNEYS

Certified to be the Drawings referred to in the Specification hereunto annexed